



2022-2023

The 14th Robot Design Contest

Rule Book

Table of Contents

Table of Contents	2
Preface	3
Overview	4
Theme	4
Safety	4
Terms and Definitions	5-7
Terms	5-7
Definition	5-7
1. Contest Outline	8
2. Game Procedure and Competition Task	9-12
3. Retries	13
4. Violation	14
5. Disqualifications	15
6. Competition	16-17
7. Teams	18
8. Robots	19
9. Others	20
10. Awards	21
11. Material List	22-24
Basic Material	22-23
Additional Material	24
12. Figure	25-29

Preface

The HKUST Robotics Team participates in various robotics competitions every year, including The MATE Remotely Underwater Operated Vehicle (ROV) Competition, The ABU Asia Pacific Robot Contest (RoboCon), The NXP Cup Intelligent Car Racing (Smart Car), The Robo-One(Humanoid) and The Singapore AUV Challenge (AUV).

This Robot Design Contest is a part of the new member recruitment process for the HKUST Robotics Team. Despite the challenging task of this year's competition, which consisted of developing two different robots, training members were able to come up with amazing robot designs and there were a lot of exciting moments throughout the competition as they demonstrated their unique techniques.

The senior members of the Robotics Team supported the training members throughout the preparation and development of their robots, providing them with tutorials on electronics, mechanics and software programming. The senior members were also largely involved in organizing the competition.

The style of this rule book closely follows that of the ABU Asia Pacific Robot Contest (RoboCon) competition and the NXP Cup Intelligent Car Racing (Smart Car).

Overview

Theme

The theme of this year is inspired by 2017, 2018 and 2022 ABU Robocon, while it merges some of the well-known features from the MATE ROV competition and NXP Cup Smart car competition. This year's game features two (2) robots, one (1) semi-auto/manual Task Robot (TR) and one (1) Auto-Racing Car (ARC). The duty of TR consists of three (3) main tasks: grabbing pieces, shooting/putting the pieces to the Tic-Tac-Toe area and defending. TR also has an optional task which is Lagori Task. Meanwhile, ARC would focus on the racing task on the specific track of the game field. In the game, two teams play against each other on the same field. The TR needs to grab the pieces, and it can also perform defensive tasks optionally, while ARC is racing against the opponent's ARC. In order to end the game, TR is required to shoot/put pieces in the Tic-Tac-Toe area and place three of them in a horizontal, vertical, or diagonal row successfully.

Safety

Safety is the top priority of the competition. During the construction of the robot, participants are required to be aware of safety.

Terms and Definitions

Terms	Definitions
Task Robot (TR)	A manual or semi-automatic robot that must perform picking up and shooting/putting pieces, while can perform defensive tasks and the lagori task optionally.
Auto-Racing Car (ARC)	An automatic racing car that performs racing against an opponent's racing car on the given track.
Racing Track Area (RTA)	The track that is for the ARC to race on. ARC must follow the curve on the track without going out from the boundary. There may be some random obstacles on the track.
Starting line (SL)	The line that ARC should stay behind before start. It is also the start line for ARC when ARC retries.
Starting Zone (SZ)	The starting area for TR is sized at 650mm×650mm. When the robot retries, it is also the Retry Zone for TR.
Loading Zone (LZ)	The area where at most three pieces can lay up at the same time. There will be no rack/tool to hold them but a team can have a self-made tool/rack to hold the pieces when TR is loading them .
Shooting Area (SA)	The area where the TR can only stay to shoot if it did not perform the lagori task.
Pieces	Props for putting/shooting in the Tic-Tac-Toe area. Red piece is for the red team while the blue piece is for the blue team. The team can load the pieces by themselves in any orientation. Team can make a tool/rack to hold those pieces in the loading zone.
Golden Pieces	Props for putting/shooting in the Tic-Tac-Toe area after the team gains the replacement opportunity. Each team will be only given one golden piece. Red team will be given a golden red piece while the blue team will be given a golden blue piece. After a team gains the replacement opportunity, TR needs to go to the SZ and the game field member(s) can load the golden piece on the TR. Once the golden piece is being used(left TR after being shot/put), it cannot be reused.
Fences	Barriers that are used to restrict the movement of the robots. Robots cannot touch the top surface and outer (or opposite) side of the Fence. However, they can touch the inner side of the Fence.

Lagori Disk	A cylindrical disc with diameter 200mm and 200mm high. The material is Polyurethane Foam of density 14 kg per meter cubed. Note that “top” and “bottom” surfaces of each disc are uncollated.
Lagori Area	The yellow zone that the lagori disk places before the game starts.
Lagori Base	A square base of size 500mm x 500mm and 200mm high.
Tic-Tac-Toe Area	It consists of nine (9) square boxes and placed in the middle of the game field.
Boxes	A large square-shaped container for holding pieces thrown/put by the TR. Each box is 380mm x 380 mm and 380mm high with some sponge inside.
Auto-Shortcut (ASC)	A shortcut from SZ to LZ that can only be used when the TR is in autonomous mode or an autonomous state exclusively.
Shooting	A successful shooting means either the piece is shot into the Tic-Tac-Toe area without hanging on the boxes.
Lagori Task	Using any means without violating the rules to put the lagori disk on the base. The orthogonal projection of the lagori disk should be within the base. For putting the lagori disk on the baase, the base of the lagori disk is not a must to contact with the top surface of the base. The disk should be fully stopped on the base for three (3) seconds.
Great Victory	The team occupies three of the boxes in a horizontal, vertical, or diagonal row of the Tic-Tac-Toe area.
Occupy a box	The team can occupy a box of the tic-tac-toe area if its pieces are put/shot to the empty box. It is on a first-come-first serve basis. The box will be locked by the team unless the opponent team shot/put the golden piece in the box using a replacement opportunity.
Replacement Opportunity	A Replacement Opportunity will be given once your team ARC has raced four (4) laps successfully in a faster time. This opportunity can be used to replace an opponent's occupied square. There will be only one replacement opportunity in each game.

Re-occupy a box	After a team gains the replacement opportunity, that team's TR shoots/puts the golden piece on the box that is occupied by the opponent team. The box will be re-occupied by the team.
-----------------	--

1. Contest Outline

- 1.1. A game between two (2) teams takes place within three (3) minutes. Each team has two(2) robots:
 - 1.1.1. Task Robot (TR)
 - 1.1.2. Auto-Racing Car (ARC)
- 1.2. The game field consists of the following zones or paths: the Starting Zone (SZ), the Loading Zone (LZ), the Racing Track (RT), the Lagori Area (LA), the Tic-Tac-Toe Zone (TTTZ), and the Auto-Shortcut (ASC).
- 1.3. The fence encloses the half-field for each team and the whole game field. Under no circumstances, robots are allowed to enter the opponent's half-field.
- 1.4. The racing track is located in the outermost part of the game field.
- 1.5. Nine (9) pieces and one (1) golden piece will be given to each team at the start of the game.
- 1.6. Three (3) pieces can be placed in the LZ during the 1 minute preparation time. During the game, after picking up/loading the first three (3) pieces, each team would be allowed to place another three (3) pieces in the LZ. And so on until all nine (9) pieces are used.

2. Game Procedure and Competition Task

2.1. Game field facility and scoring object:

- 2.1.1. In this game, there is only one (1) winning method: shooting/putting pieces into boxes of the Tic-Tac-Toe area. Please note that finishing the lagori task will not gain any score.
- 2.1.2. The winning objects in this game are pieces.
- 2.1.3. Therefore, the game field facilities are lagori disk, lagori base, Boxes, Racing Track (RT), Pieces and Golden Piece. Their dimensions are specified in Section 12 of this rule book.
- 2.1.4. Team members are not allowed to touch any of the game field facilities during the game, except reloading the pieces on the LZ.

2.2. Before the game starts

- 2.2.1. After the teams enter the competition area, they should put their robots next to the Game Field.
- 2.2.2. Before a game begins, a one-minute preparation time is given to each team through the signal from the main referee. After the preparation time begins, the team members should put their robots in the corresponding starting area on the Game Field respectively and preload 3 pieces on the Loading Zone.
- 2.2.3. Each team is allowed to have 3 Game Field members and up to 3 pit crews for the set-up.
- 2.2.4. If a team fails to set up their robot within the one-minute Preparation time, they may resume set-up after the game starts, Once the set-up is finished, the team can start their robots with the permission of the referee. But no extra time will be given.
- 2.2.5. Before the start of the game, all team members should leave the Game Field once they finish setting up the robots as soon as possible. They must withdraw from the game field once the game starts.
- 2.2.6. The controller for TR must be put on the ground before the game starts.
- 2.2.7. The referees will indicate the start of a game with whistles and raising flags.

2.3. At the start of the game and during the game:

- 2.3.1. TR must completely fit into the Start Zone and include the space above the StartZone. At the beginning of the Game, TR must stay there.
- 2.3.2. The motors of the Auto-Racing Car must remain still when handled by a game field member before starting and may only start spinning a second after the member releases the car. The car must not be pushed to start, or by any other means that involves touching the car during or after the motors start spinning. Game Field members must leave the Game Field once ARC is released.
- 2.3.3. All team members must be outside of the Game Field, but this rule is not applicable under the circumstances mentioned in Rule 2.2.4 and Retries.
- 2.3.4. During the one-minute preparation time of the game, three (3) pieces shall be arranged on the LZ by game field member(s). The remaining nine (9) pieces will be located outside and next to the corresponding half field of each team. One (1) golden piece

will be located near the start zone outside the game field.

There should be at most twenty-four (24) pieces and two (2) golden pieces on the game field simultaneously at any time.

- 2.3.5. During the game, only when the Loading Area has NO pieces on it, Game Field members can reload another three (3) pieces onto the Loading Area until all pieces are loaded. All game field members must leave the Game Field immediately after loading pieces.
- 2.3.6. The Auto-Shortcut is designated for encouraging automation in robots. TR can ONLY access the Auto-Shortcut when in automatic mode after seeking permission from the referee exclusively. After permission is granted, Game Field members can start the autonomous function or change to autonomous mode. Game field members should leave their controllers on the ground when TR is on the ASC. This rule is also applicable to TR for going from Loading Zone to Starting Zone, and after Retries.

2.4. Task of Robots:

2.4.1. The task of TR:

There are three types of tasks that TR can perform during the game: the normal tasks: grabbing the pieces and shooting/putting the pieces, lagori tasks and the defensive tasks.

- 1) After the game starts, TR can move out from the TR Start Zone.
- 2) TR can go to the LZ manually or automatically. If the TR goes to LZ automatically inside the ASC, it can take the pieces three at once, otherwise, TR only can take the piece one by one. If TR goes to LZ automatically inside the ASC, once it touches the LZ, it can change from automatic mode to manual mode.
- 3) TR must go to the SA to shoot the pieces to the boxes in the TTTZ. The orthogonal projection of the robot can exceed the SA. But, it can only throw one (1) piece each time. Before the piece enters the box or lands somewhere, it cannot throw out the next piece.
- 4) TR cannot shoot/put the pieces in the TTTZ outside the SA unless it performs the lagori task. After performing the task, the TR can be “unlocked” and walk in its team’s area. TR is allowed to extend into the space above the TTTZ and put the pieces inside the box one by one.
- 5) TR can pick the nine (9) given pieces in the LZ.
- 6) TR can pick up their pieces that landed on the ground outside the tic tac toe area on its team’s half game field.
- 7) TR cannot use the pieces that are thrown by the opponent and land on its team’s half game field. If TR throws the opponent team’s pieces in the empty box. That box will be occupied by the opponent team.
- 8) If a team gains a replacement opportunity, the team can preload one golden piece to TR in the start zone when TR is completely fit inside the start zone. Once the golden piece is being used(left TR after being shot/put), they cannot be reused and the replacement opportunity will be used up. There are only four (4) scenarios of the golden piece:
 - i) The golden piece is shot/put on the empty box, the box will be occupied by the team.

- ii) The golden piece is shot/put on the box that its team occupied, there is no change in the occupied box situation.
 - iii) The golden piece is shot/put on the box that the opponent team occupied, the box will be re-occupied by the team.
 - iv) The golden piece is shot/put outside the box of the TTTZ, there is no change in the occupied box situation.
- 9) During the game, TR is not allowed to enter or extend into the opponent team's half field including its above space. It can only extend into the space above the outside Fence for a short period.
- 10) TR can perform defensive tasks with the following means:
- i. Defense with a waving part to intercept pieces which the opposing team throws to the boxes of the Tic-Tac-Toe area. But, when it waves to intercept pieces, it must not violate any of the following:
 - a) The surface area of the part that is used to intercept pieces shall not exceed 40000mm² at any face.
 - b) The orthogonal projection of TR's any part to the ground must not overlap with the opponent's half field.
- 11) However, TR must not perform any of the following:
- i. TR makes use of any part of the robot other than the part that strictly follows Rule 2.4.1 10) i., to block pieces from the opponent team intentionally.
 - ii. TR to directly remove the opponent's pieces from the box in tic-tac-toe area in any way
 - iii. The team intentionally makes use of its size to block pieces or the vision of the opponent team from a design perspective.

2.4.2. Task of ARC:

There is only one task that ARC can perform during the game, which is to move along the smart car track. This is the task that ARC should perform to compete with the opposing ARC to gain a replacement opportunity.

- 1) Before the game starts, the ARC should be placed behind the starting line. The starting positions of both ARC can be shown in the following picture.

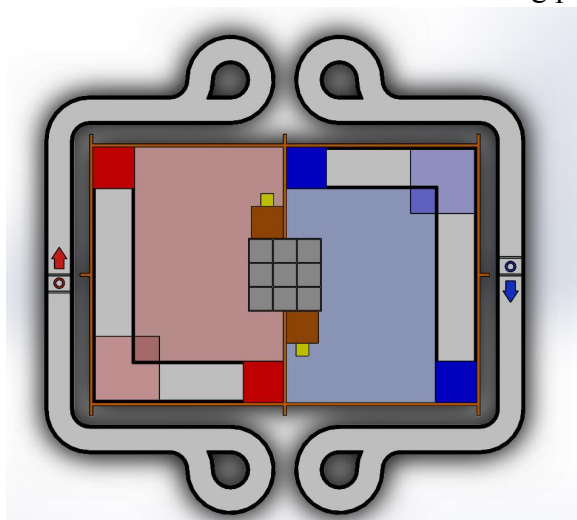

- 2) During the game, the ARC needs to move along the ARC track.
- 3) ARC needs to race for 4 laps in order to compete for the replacement opportunity. The faster team can gain the replacement opportunity. The definition of one lap is shown in the following picture. Please note that the path of this picture is just an example.

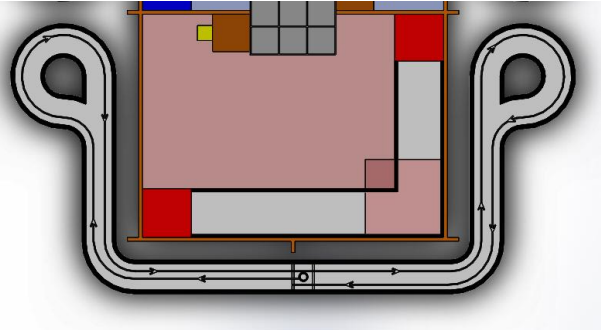

- 4) During the game, any pieces on the ARC track will not be removed. The ARC needs to avoid the pieces during the race.
- 5) The ARC must be autonomous and cannot be remotely-controlled. During the race, the ARC cannot be fitted with any wireless connectivity. Connectivity is allowed only during training sessions to help monitor the ARC and run diagnostics during the development but must be removed from the ARC kit.
- 6) Any of the following will lead to the lap not being counted:
 - i) The ARC exits the ARC track
 - ii) Any part of any wheel leaves the racing surface
- 7) The ARC can be repositioned on the smart car track to perform the task after it exits the track. However, the ARC must be placed behind the starting line.

2.5. Deciding the winner

2.5.1. At the end of the game, the winner will be determined in the following order:

- 1) The team that achieves “Great Victory”;
- 2) The team with higher number of occupied square;
- 3) In case of a tie, the winner will be decided according to the following order:
 - i. The team which occupy the middle square wins;
 - ii. The team with more laps travelled by ARC wins;
 - iii. The team that has committed fewer violations wins;
 - iv. The team with less total weight of robots wins;
 - v. Decisions made by judges

2.5.2. When the game ends, the temporary scores of both teams will be announced.

2.5.3. There will be a 30-second countdown after a game ends. Teams may appeal if there is any doubt about the game. Teams are not allowed to appeal after the 30-second countdown. The finalized score and the winner of the game will be announced then.

3. Retries

- 3.1 Game Field members must request permission to retry by raising hand/flag and shouting “Retry”.
- 3.2 A retry is allowed only after the referee gives permission upon request from a team member.
- 3.3 If a robot falls into fault or a task is not completed, the team can apply for a retry of the robot. The retry can only be made only after the referee’s permission.
- 3.4 If a robot violates the rules, the robot should make a compulsory retry as directed by the referee.
- 3.5 When preparing for a retry, the team members must place the robot that needs to retry at an assigned location. The retry location of TR is TR Start Zone. The retry location of ARC is behind the starting line. If a team’s TR or ARC makes a false start, then the TR and ARC have to all go back to their respective Start Zones and restart when retry.
- 3.6 During retry, the team members can adjust and change the position of the pieces carried on the robot.
- 3.7 In the retry, the team members are not allowed to pick up pieces that have fallen anywhere.
- 3.8 There are no limits to the number of times for retry. Retry must be done according to the rules with approval from the referee.

4. Violation

The team who commits the following shall be deemed to be in violation of the rules and subject to a mandatory retry. The referee will shout 'violation' if a violation is committed.

- 4.1. Any part of any robot exits the Game Field.
- 4.2. The pieces are shot/put outside the Game Field by TR.
- 4.3. The lagori disk is put to the opponent's team half field or put outside the Game Field by TR.
- 4.4. Any robot enters into the opponent's half field and extends into the space above it.
- 4.5. The team makes a false start.
- 4.6. Other actions that infringe on the rules but without mentioning in the disqualifications are considered as a violation.
- 4.7. In case of a violation committed by TR, the laps travelled by ARC will still be counted during the retry of TR.
- 4.8. ARC can retry separately when only ARC causes a violation.

5. Disqualifications

The following actions will lead to disqualification and the opponent team immediately wins the game:

- 5.1. The design and build of the robot are not in accordance with the regulations in Section 8.
- 5.2. The team intentionally damages or tries to damage the field, facilities, game objects or opponent's robots.
- 5.3. The team performs any acts that are not in the spirit of fair play.
- 5.4. The team fails to obey instructions or warnings issued by referees three times
- 5.5. Any robot entirely leaves the game field. But this is not applicable when a retry is requested before the robot entirely leaves the game field.

6. Competition

6.1. The whole contest will be conducted face-to-face for all members.

6.2. The game flow of the competition:

6.2.1. The competition will be conducted in double-elimination tournament, each team will play against other teams with 2 stages: Winner Bracket and Loser Bracket.

6.2.2. Winner Bracket

- 1) Every team will start with the Winner Bracket stage in the competition.
- 2) Winner team in Winner Bracket match will be arranged to next Winner Bracket match
- 3) Loser team in Winner Bracket match will be arranged to next Loser Bracket match
- 4) The placement in the finals will be given to the last team in the Winner Bracket stage.

6.2.3. Loser Bracket

- 1) Winner team in Loser Bracket match will be arranged to next Loser Bracket match
- 2) Loser team in Loser Bracket match will be defected in the competition
- 3) The placement in the finals will be given to the last team in the Loser Bracket stage.

6.2.4. Final Round

Winner will be decided in the following situations

- The team from the Winner Bracket stage win in the first round
- The winner team in the second round, which will be delivered if the team from the Loser Bracket wins in the first round.

The complete game flow is described in the following flow chart.

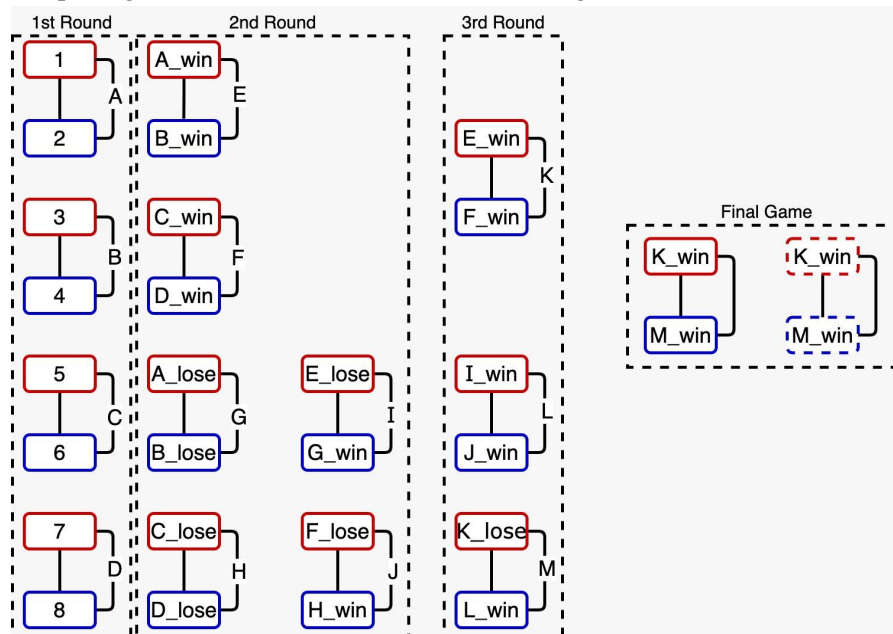

6.3. Final Presentation and Poster Design

6.3.1. The presentation will be held before the match, with each team presenting for 10 minutes.

6.3.2. A total of 9 scoring categories, with each category holding a score of 0-4 points.

6.3.3. A scoring sheet will be given to participants well before the presentation for their preparation.

6.3.4. Scoring Sheet

1) Preparation

- All team members contributed to and were well prepared for the presentation.

2) Delivery

- Presentation was dynamic, clear and informative.

3) Content

- Presentation demonstrated a well understanding of the contest and described the group's game plan.
- Presentation clearly explains an overview of their values (Designs, Innovation, etc) and how its built
- Discussed the extent to which the TR and ARC was tested prior to the contest

4) Teamwork

- The Demonstration project was a collaborative effort with each member contributing.
- Members are supportive of each other and self-teaching/mentoring is demonstrated.

5) Lessons Learned

- Described most significant technical lesson learned, can be related to a challenge encountered.
- Described most significant interpersonal or management lessons learned, can be related to challenge encountered.

7. Teams

- 7.1. All team members are 2022/2023 candidates of the HKUST Robotics Team and are HKUST undergraduates.
- 7.2. Team members can be from any school, year, or department.
- 7.3. Each team is assigned mentor(s) for handling team affairs.
- 7.4. Each team will consist of 4 mechanical members, 4 hardware members, and 4 software members.
- 7.5. Each team consists of three (3) students, called Game Field members to participate in the game.
- 7.6. In addition, three (3) members are allowed to be registered as the pit crews and to assist in the pit area, to carry the robots to the field, and participate in the setting of the robots.

8. Robots

- 8.1. Each team is allowed to design 1 Task Robot and 1 ARC.
- 8.2. The robots must not split into separate parts during the game.
- 8.3. The ARC must be fully automatic.
- 8.4. Robot sizes
 - 8.4.1. The Task Robot should not exceed **650mm×650mm×650mm** (width × length × height) at the start of the game.
- 8.5. Robot weights
 - 8.5.1. The total weight of the Task Robots including batteries, compressed air, containers, and the controller if there is one, must not exceed 18kg at the beginning of the game.
- 8.6. The power source of the robots
 - 8.6.1. All batteries used in robots should not exceed 12.6V.
 - 8.6.2. The maximum voltage on the circuit(s) should not exceed 24V.
 - 8.6.3. Compressed air should be filled into PET bottles and must not exceed 6 bars (600kPa).
 - 8.6.4. Dangerous energy sources (such as high-pressure gasses) and explosives are prohibited.
 - 8.6.5. An emergency stop button with a 20A fuse must be installed.
- 8.7. If the referee determines that the robots may injure any people or cause damage or harm to the game field, the game may be ended immediately.
- 8.8. Sensors allowed for the ARC are as the followings:
 - 1) IR Sensor
 - 2) Line Tracking Sensor
 - 3) Camera
 - 4) Time-of-Flight Sensor

9. Others

- 9.1. For anything not mentioned in this rule book, the teams are required to accept the decisions of the HKUST Robotics Team.
- 9.2. The dimensions, weights, etc of the field, facilities, and equipment described in this rule book have a margin of error of 5% unless otherwise stated.
- 9.3. All robots must pass requirements of dimension, weight and safety checks in order to take part in the contest.
- 9.4. Teams may be required to demonstrate all functions of the robots in the final presentation.
- 9.5. The referees may demand additional explanations on safety issues when the safety of a robot is deemed to be in question.
- 9.6. All questions should be addressed to the Q&A link:
<https://forms.gle/wtQGGHDZbfXM52xn6>
- 9.7. Any changes to the rules will be announced through Google Drive. Participants are responsible for checking for the latest information.
- 9.8. The HKUST Robotics Team will provide basic materials and tools for each team.
- 9.9. Usage of materials and tools not provided by the contest are required to be approved by the Contest (Ask in FAQ section) and supplied by team members themselves.
- 9.10. The materials and tools provided by the HKUST Robotics Team must not be disclosed to the public or external organizations without permission.
- 9.11. Usage of materials and tools not provided by the contest are required to be approved by the Contest (Ask in FAQ section) and supplied by team members themselves.

10. Awards

There are 5 awards in the contest:

- 10.1. **Champion**
- 10.2. **First-Runner Up**
- 10.3. **Second-Runner Up**
- 10.4. **Best Engineering Award:** The award shall go to the team which has the highest total score from the Mech, Hardware and Software division.
- 10.5. **Best Presentation Award:** The award shall go to the team which has the best presentation. The presentation is referring to the Final Presentation at the end of December.

11. Material List

11.1. Basic Materials

The following items are the basic materials every team can have in designing their Robot:

- a. 19mm //x 19mm aluminium tubes
- b. 20mm x 20mm aluminium tubes
- c.

Material	Quantity
Smart car kit	1
OV7725 camera	1
Carbon fibre rod for mounting camera	1
Pole mount, camera mount stl file set	1
Motors (RM m3508 P19)	3
motor mounts	3
lock bushes	3
2 straight wheel (white rubber) / 3 Omni wheels	1
coweye	1
2 cells 7.4 V Li-Po battery (For ARC)	1
3 cells 11.1 V Li-Po battery (For TR)	2
STM32 mainboard	2
RM C620 ESC	3
Power Management Board	1
TFT display	2
Bluetooth Module (HC-05)	2
ST-Link (if lost, have to pay \$30 for each)	2
On-Off switches	2
Emergency stop button (e-stop)	1
Fuse socket	3
Battery voltage level monitor (beeper)	2

Mech toolbox (2 M3 flat end, 1 M3 ball end & 1/2 M4 hex keys, 2 spanners, 1 adjustable spanner, 1 cross socket spanner)(# If lost any equipment in the mech tool box and would like to have replacements, a penalty fine will be imposed and immediate stock is not guaranteed.)	1
Game prop.s for RDC (piece) (need to return on the competition day) (if lost, \$9 for each) (if broken and would like to replace use credit to buy)	1
Solenoid valve	2
TOF(VL53L1)	1
basic glass fibre connector set	1

- d. pneumatic cylinders, models are uncertain, ask for more detailed arrangement from your seniors
- e. glass/ carbon fibre connectors, ask for more detailed arrangements from your seniors
- f. Nuts & screw, basically unlimited, ask for more detailed arrangements from your seniors

DO NOT steal tools and components from other teams. Most mechanical components found in Hall 9 are allowed to be used and you should only take what you need. If you are not sure whether the components can be used, ask seniors first.

11.2. Additional Materials

Other than the basic materials that are provided, we also provide a list of additional materials. You can buy them with credits. Each team initially has 1000 credits. All items have limited stock. A representative of the team can buy their required items through <https://forms.gle/af68vBgfhKVjpir96>

The following are materials that can be purchased by credits.

Number	Materials	Credits
1.	Line Tracking Sensor	40
2.	IR Proximity Sensor	80
3.	Ultrasonic Sensor	100
4.	Limiting Switch	100
5.	TOF sensor(VL53L1)	120
6.	OV7725 camera	150
7.	3D- printing (per gram)(*max 100g in total for each team)	2
8.	Piece (if and only if the original piece is broken)	75
9.	change wheelset	200
10.	Solenoid valve	200
11.	Slider	50
12.	Machine part found in hall 9	100
13.	Mainboard (Soldered)	100

You may propose some extra types of material and ask for approval in the FAQ. If it is approved, all teams would be allowed to use that, but it should be self-provided.

*The software library and motor mount for the motor will not be provided.

Candidates need to prepare them by themselves.

12. Figures

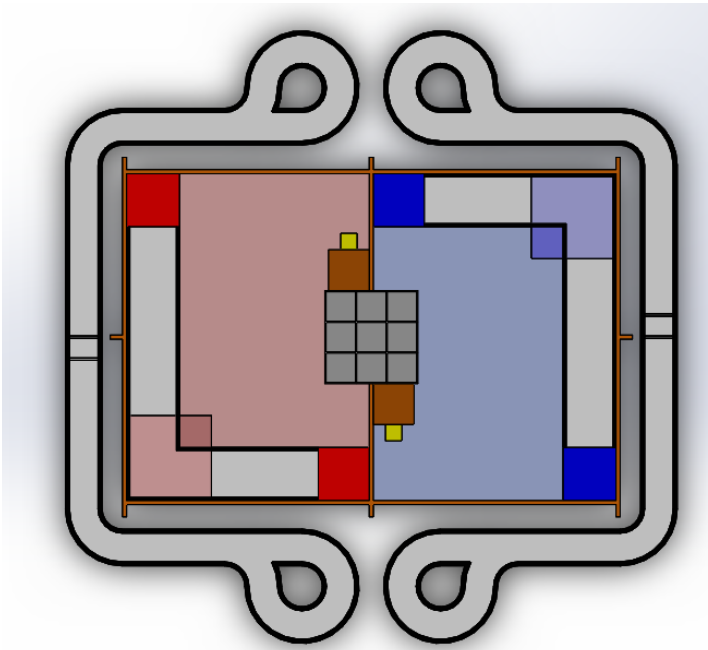

Fig. 1.1: Game Field

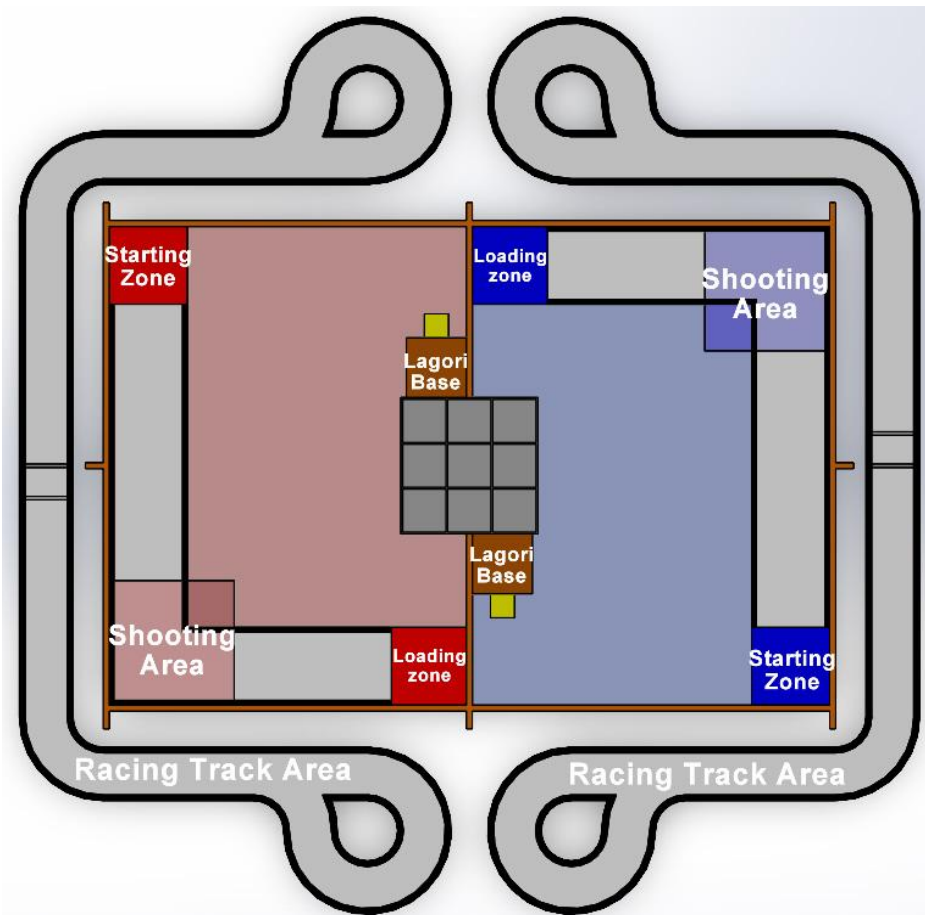

Fig. 1.2: Game Field and its function areas Part 1

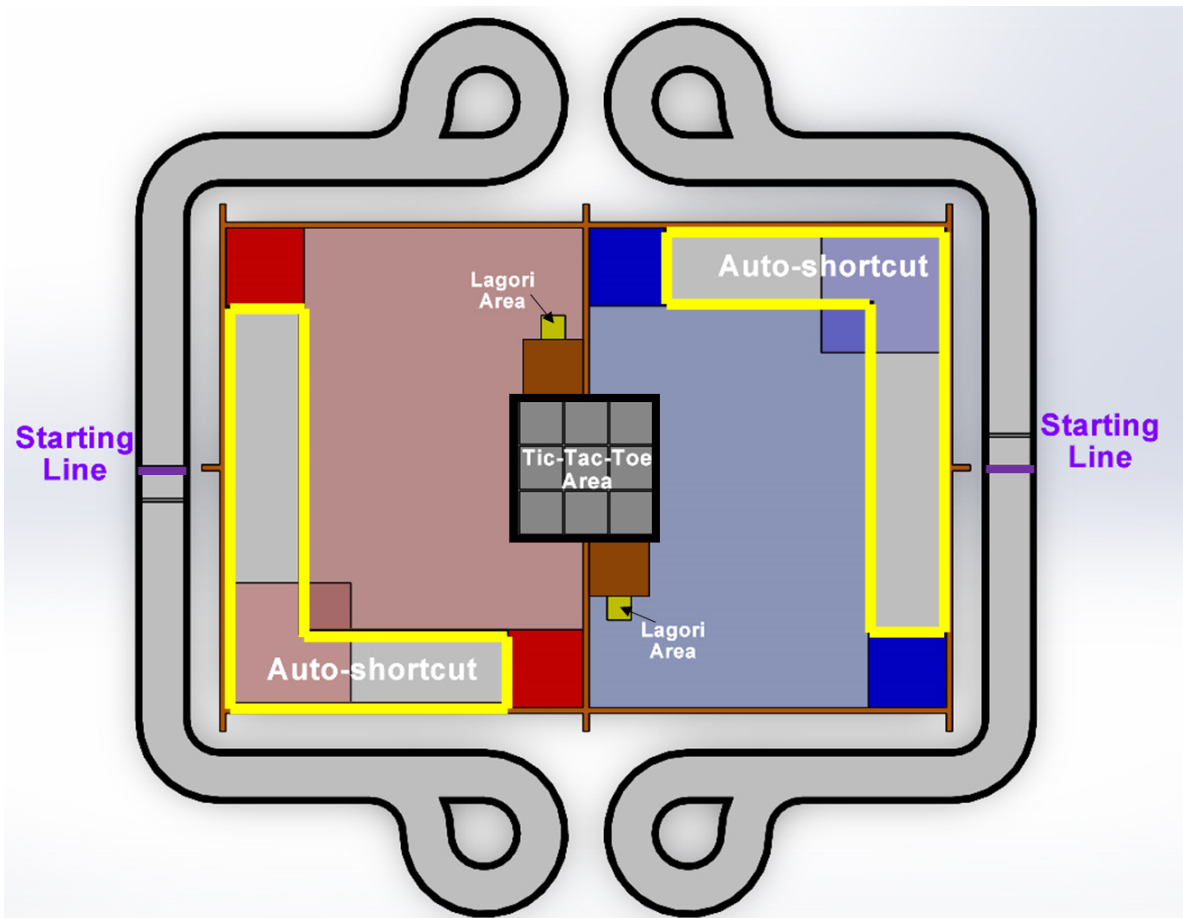

Fig. 1.3: Game Field and its function areas Part 2

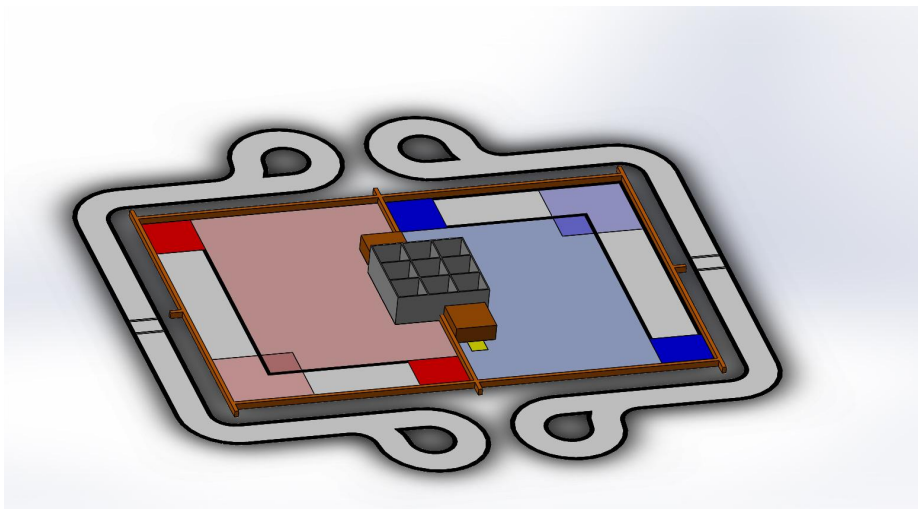

Fig. 2: Game Field (Perspective View)



Fig. 3.1: Pieces

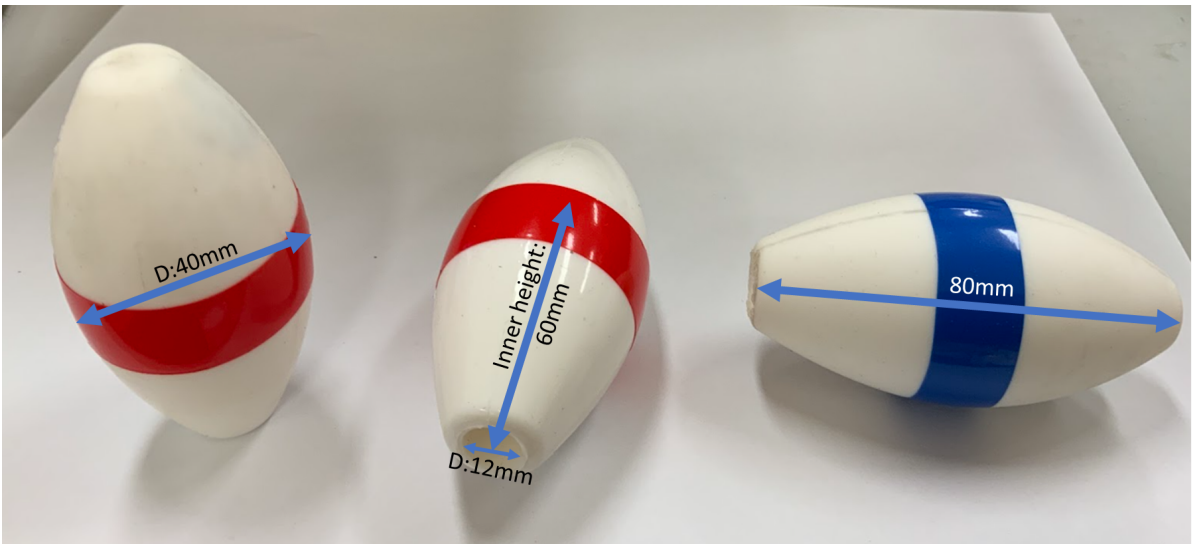

Fig. 3.1: Pieces with dimension

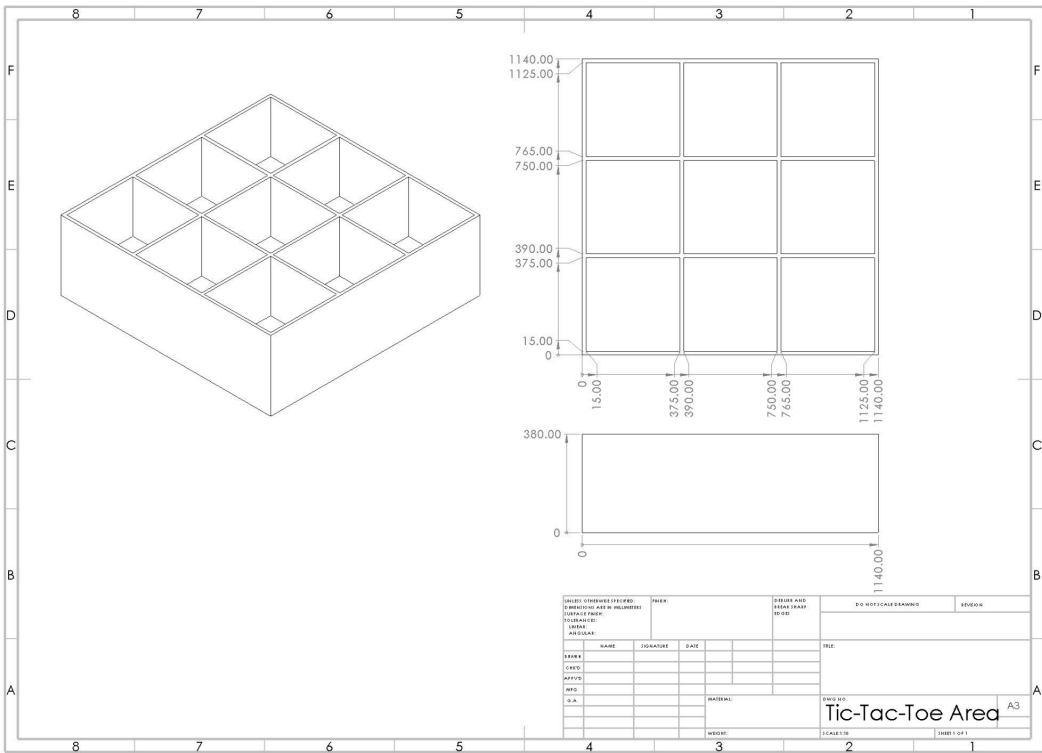

Fig. 6: Tic-Tac-Toe Area

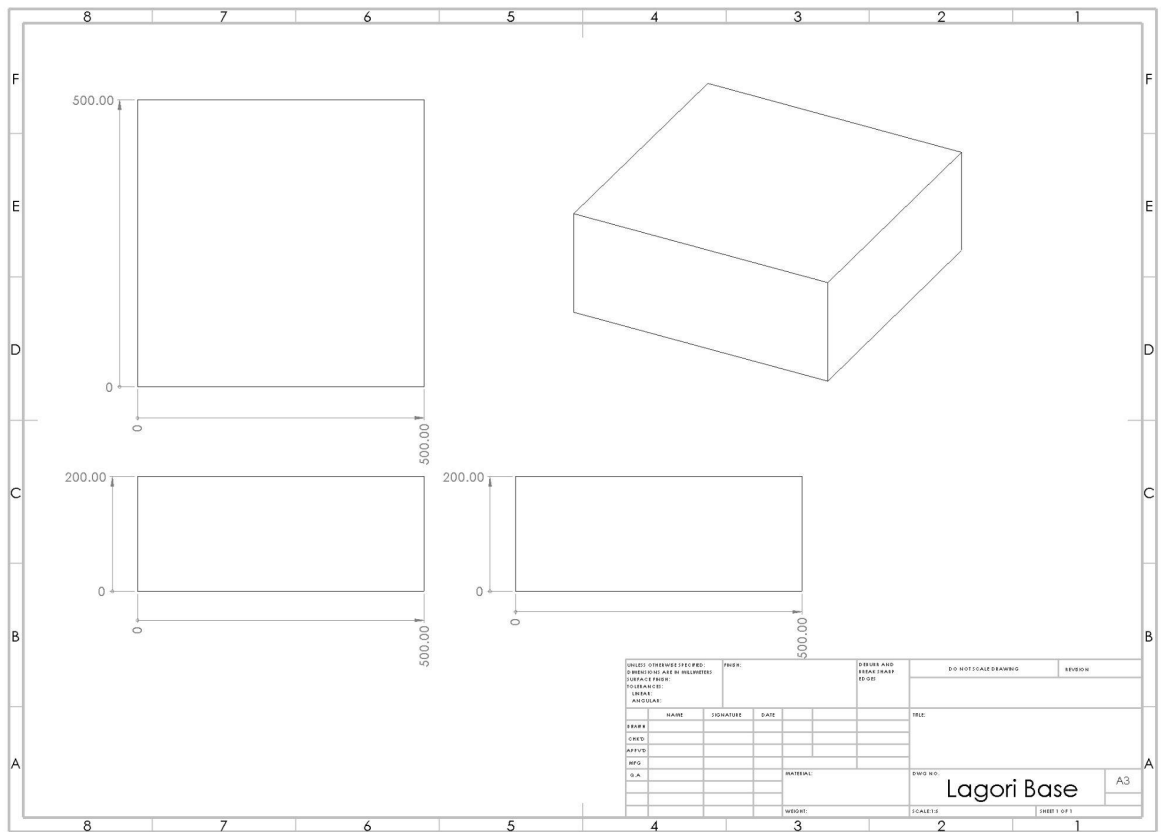

Fig. 7: Lagori Base